

motor. This includes motor tune-up procedures to keep the motor in prime operating condition.

3. COMPLETE DISASSEMBLY and overhaul, such as inspecting a motor that has been submerged, or rebuilding trade-in units.

It is important to you as the service man to determine before disassembly just what the trouble is, and how to correct it quickly and with minimum expense to the owner. Refer to the Trouble Check Chart in Section 2 to help you diagnose motor malfunctions.

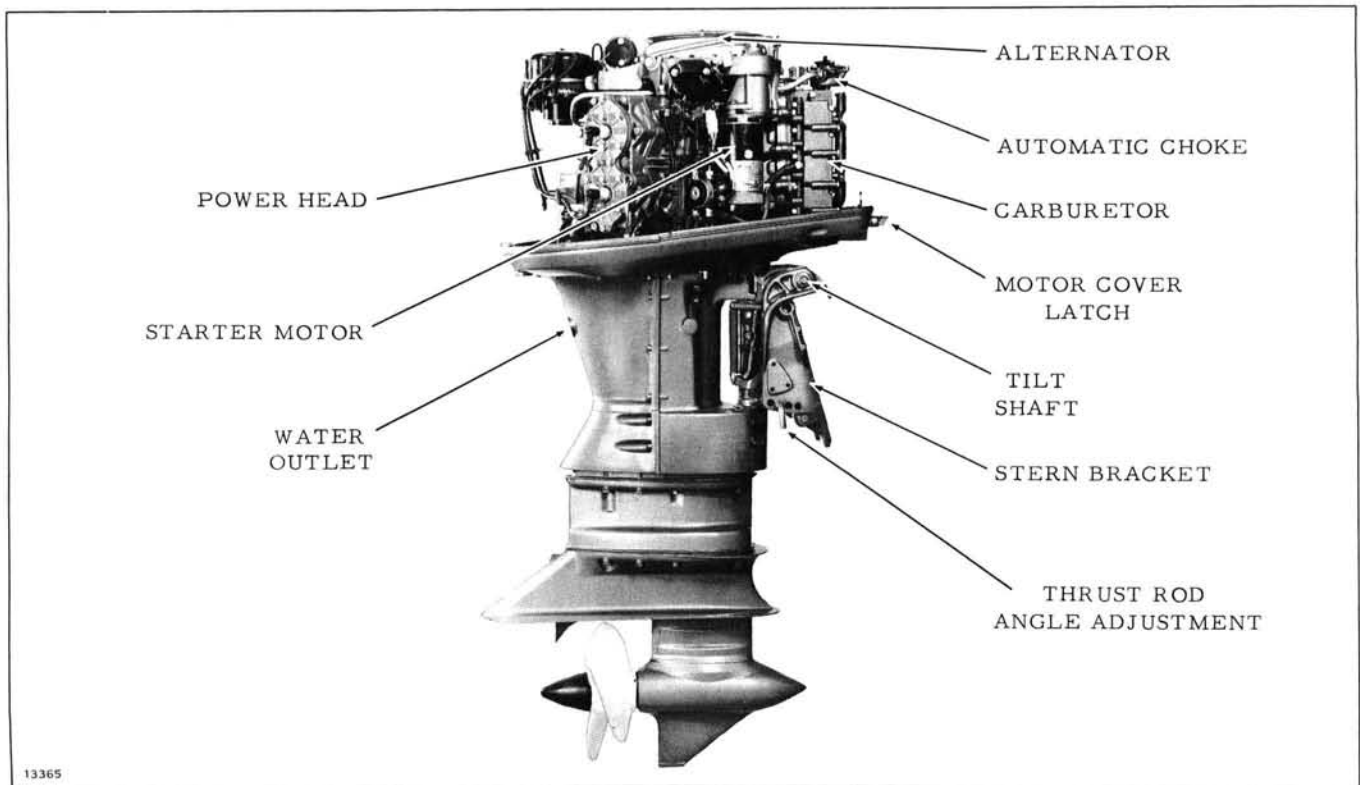

13365

Figure 1-1. Starboard Side

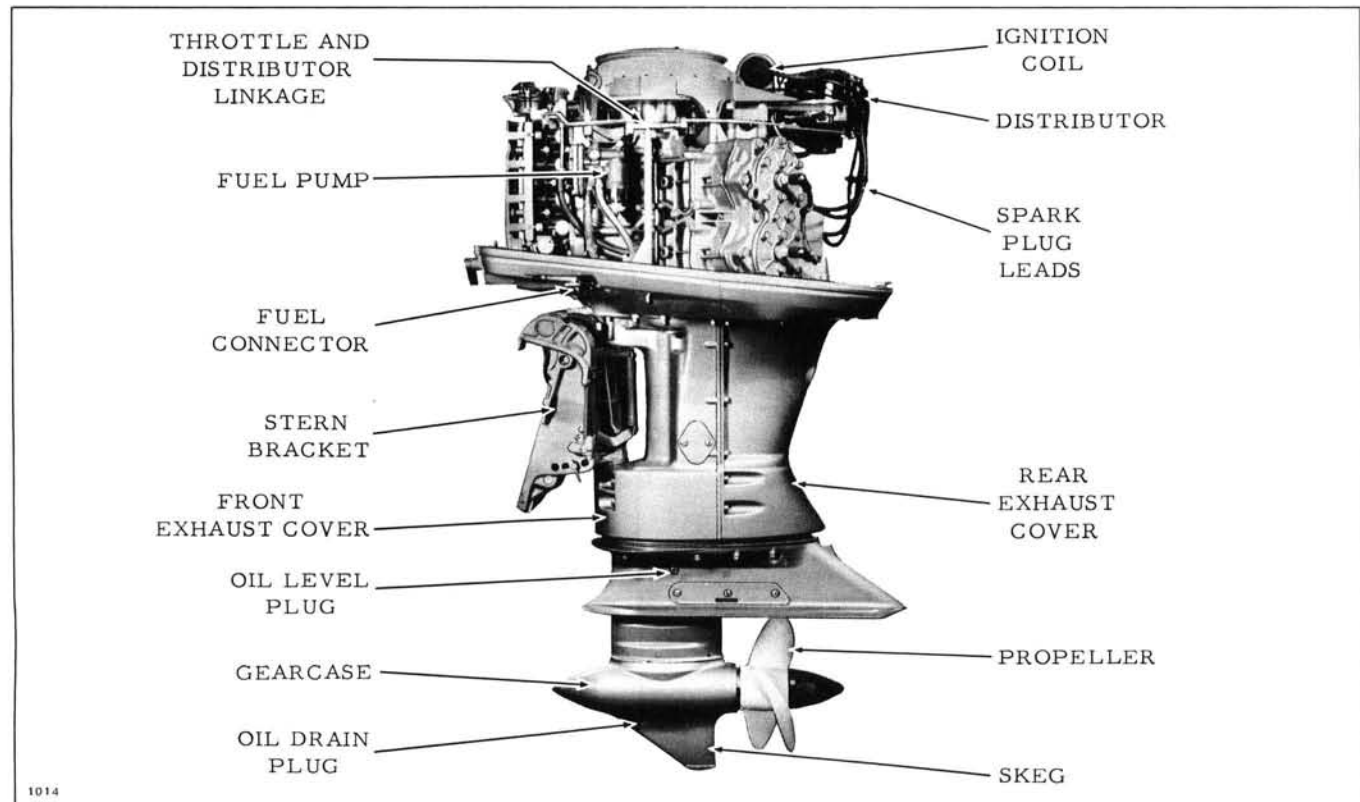

1014

Figure 1-2. Port Side