

CRANKCASE/CRANKSHAFT/TRANSMISSION

GEAR TOOTH CONTACT PATTERN CHECK

Remove the output shaft assembly and apply Prussian Blue to the output shaft gear teeth.
Install the output shaft assembly and rotate the countershaft several times in both directions of rotation.

Remove the output shaft assembly again, and check the gear tooth contact pattern.

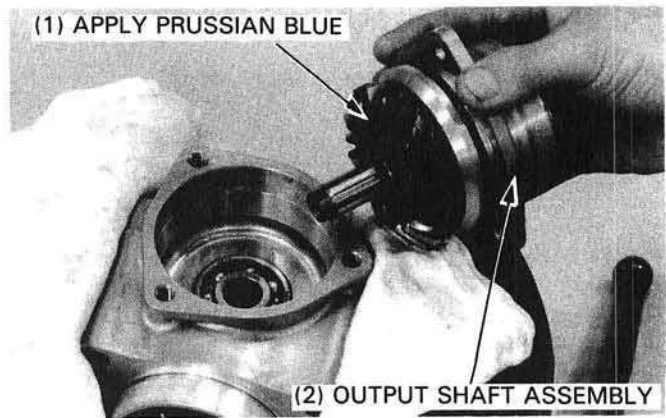

Contact is normal if Prussian Blue is transferred to the approximate center of each tooth and slightly to the side.

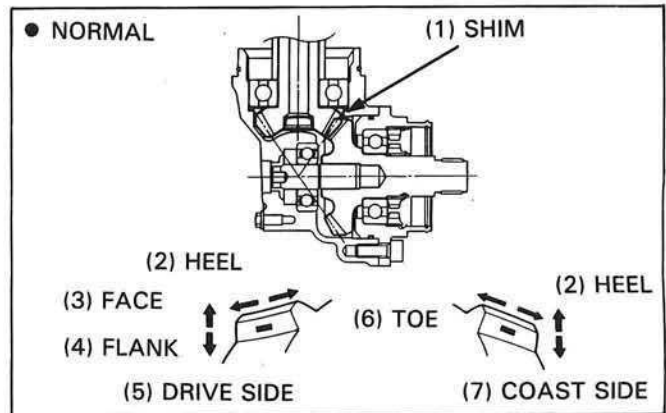

If the pattern is not correct, remove and replace the countershaft adjustment shim (page 10-21).

Replace the shim with a thinner one if the contact pattern is too high.

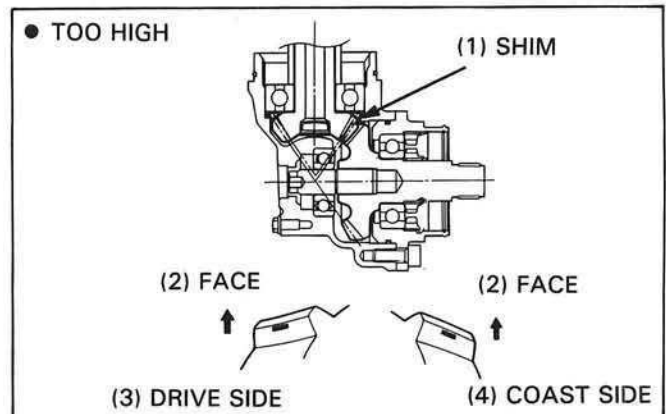

Replace the countershaft adjustment shim with a thicker one if the contact is too low.

The pattern will shift about 1.00 mm (0.039 in) when the thickness of the shim is changed by 0.10 mm (0.004 in).

OUTPUT DRIVE GEAR ADJUSTMENT SHIMS:

- A: 0.80 mm (0.031 in)
- B: 0.85 mm (0.033 in)
- C: 0.90 mm (0.035 in)
- D: 0.95 mm (0.037 in)
- E: 1.00 mm (0.039 in) Standard
- F: 1.05 mm (0.041 in)
- G: 1.10 mm (0.043 in)

